



GT LUX



TECHNICAL DATA SHEETS



www.guardtech.com



0330 113 0303



sales@guardtech.com



Unit C The Brocks Business Park, Homefield Road, Haverhill, Suffolk, CB9 8QP



DIRECTORY

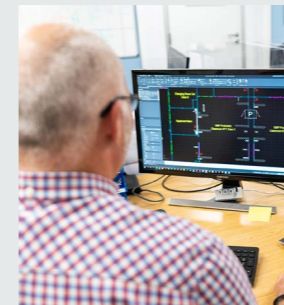

Design **pg 6**



GT Lux Max **pg 8**



GT Lux Pro **pg 12**



GT Lux Plus **pg 14**



GT Lux Lite **pg 16**



GT Lux Fire **pg 20**



DALI Controls **pg 22**



Comparisons **pg 24**

GT LUX CLEANROOM LIGHTING



Guardtech offer a range of lighting solutions to best suit the needs of your application. Whether it's budget, lead time or performance that matters most, Guardtech provide a comprehensive choice of lighting options to ensure your process requirements are achieved.

Whether it's a more economical entry-level LED panel you prefer, all the way up to a top-end DALI SmartScan lighting management system, the Guardtech Group's Directors, Design Engineers and Installation team have worked together to carefully select four industry-leading lighting options for your consideration.

Read on to discover the benefits and compromises of the different choices we have, then use this guide to make the most informed lighting choice possible.

Let Guardtech take your operation to the next level.



LUX MAX

GT Lux Max is Guardtech's elite-level light solution – a top-end luminaire offering optimum control via a Digital Addressable Lighting Interface (DALI) system or SmartScan lighting management system.



LUX PRO

GT Lux Pro is a high-quality and robust LED luminaire with a highly efficient light source – the unit opens from the top, meaning that maintenance is easy and decontamination risks are reduced.



LUX PLUS

GT Lux Plus is a highly efficient LED that has been engineered to be mounted in modular and suspended ceilings – the luminaire body is made from steel sheet and powder coated in white.



LUX LITE

GT Lux Lite is Guardtech's entry-level light solution – an LED ceiling tile lighting panel that delivers on performance while allowing clients to save their budget for other critical areas of the project.



LUX FIRE

GT Lux Fire is Guardtech's fire-rated lighting solution – a high-quality recessed LED luminaire with a corrosion-resistant, zinc-coated steel body that meets the requirements of Zone 1 hazardous areas.

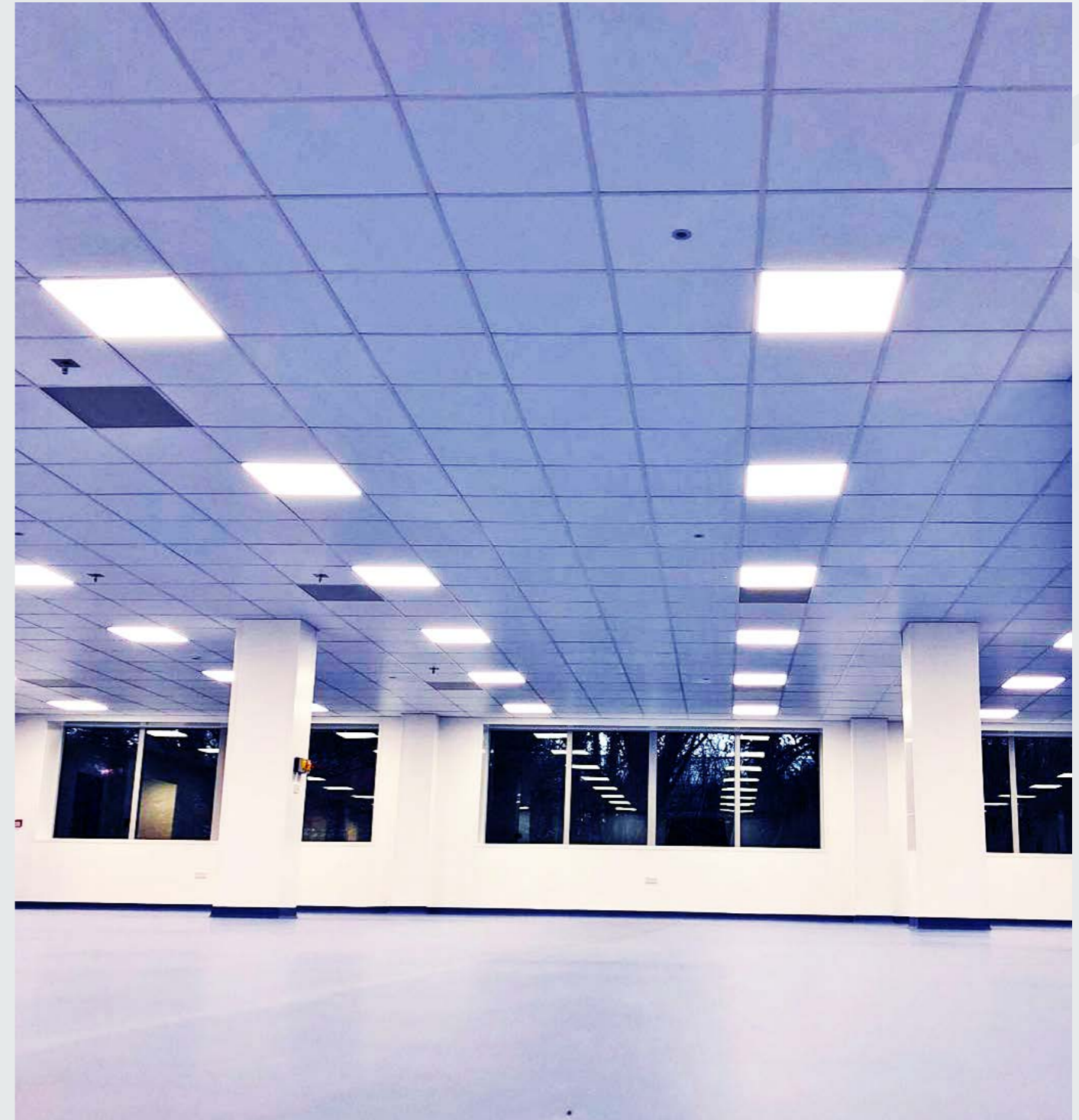

DESIGN CLEANROOM LIGHTING



Each and every luminaire is manufactured in an ISO 13485 certified facility within an ISO7 cleanroom, where the production process is conducted to the highest standard, including disinfection of particular specialist components.

Prior to manufacturing, a detailed design phase is conducted to establish the correct luminaire type and the optimal sizing and layout to deliver the performance specification required by the end user, ensuring suitability for the environment and the application.

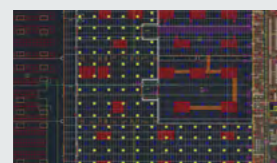

Customer and project requirements

STAGE 1: General arrangement layout with proposed distribution of luminaires. Detailed plans with sections, cuts and ceiling typology. Functions, ambience, experience, sensations, levels and creation of environments. BIM methodology.

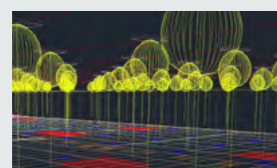

Lighting consultation, conceptualisation and project development

STAGE 2: Initial sketch of the lighting study. Plans with proposed location of luminaires. Lighting study and detailed lighting calculations to establish lux levels and uniformity. 3D modelling also available.

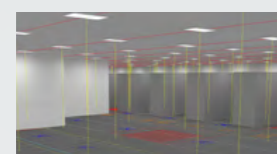

Presentation and delivery of the project

STAGE 3: Lighting levels represented in false colours. Luminaire location plan (PDF and CAD). Technical data sheets of applied products. Control and Smart Lighting services: Creation of groups and scenes, location of sensors, sketches and electrical diagrams, configuration.

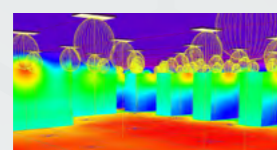

Technical support and aftercare

STAGE 4: Lighting simulation result of the final project. Follow-up of work and supervision of the installation and configurations. Maintenance and repairs. Programming and commissioning of regulation and control systems.

COLOUR INDEX

Specific colours and wavelengths can be requested to protect products such as sensitive electronic components, as well as illuminating environments to enhance aesthetics or create certain ambience.

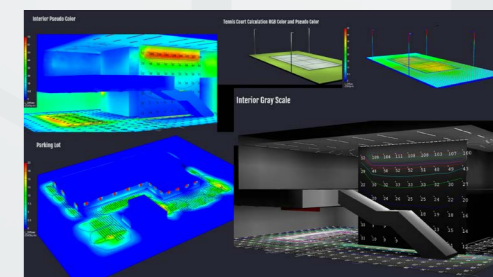
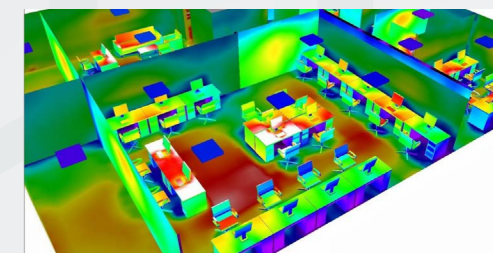
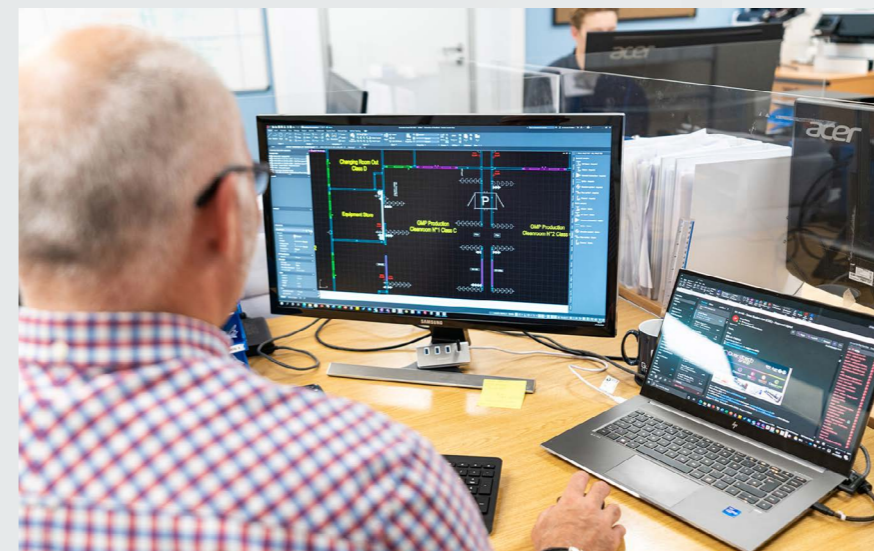

LIGHT

Colour temperature

From warm to cool, can reproduce the colour of natural light or provide high intensity stark white light. Drivers can also provide a tunable white to adjust temperature throughout the course of a day.

Colour rendering

Reproduces the real colours of an object. Specific colours can be incorporated to suit industry requirements, such as yellow for Semiconductor or red for animal labs.

Lumen

The amount of visual light emitted is especially important in medical applications where high through-puts are needed in critical areas such as surgery.

Diffuser

Gives a wide choice to control the emission and protect the fitting against dust and moisture, especially important in industry requiring high level of cleanliness.

Optic

The way the light is directed, managing reflections to ensure most of the light is focused where it is needed most.

Emission

Optimising light output to achieve best performance comfort and wellness. Direct, indirect and up and down.

GEAR

Control

On/off switch, PIR motion detector sensor, dimmer switch, DALI control system.

Endurance

For particularly harsh environments the internal components can be upgraded to a hard-wearing finish.

Emergency

Battery back-up for emergency power loss situations.

Sensors

Interaction in real time between lighting and application environment.

BODY

Size

Dimension adjusted to specific project.

Material

Sheet steel, stainless steel
Protection: IP, IK.

Finishing

Standard RAL 9016 white colour, any other RAL colour on request. Special luminaires coatings: antibacterial – crucial for high degree cleanliness rooms and anti-reflective – recommended for operating theatres where a laser light beam is used.

Installation

Installation in suspended ceilings with modular structure, in panelled ceilings, directly on the fixed ceiling.

Luminaires can be adapted to different types of ceilings with different module sizes. Suitable for installation in technical ceilings where lighting maintenance can be carried out directly without entering the room, which is particularly important in cleanrooms.



GT LUX MAX

GT Lux Max is Guardtech's elite-level light solution – a top-end luminaire offering optimum control via a Digital Addressable Lighting Interface (DALI) system or SmartScan lighting management system.



GT Lux Max is a recessed rear access luminaire with full walk-on capability. Designed to flush-fit (top and bottom) in to cut aperture composite load-bearing ceiling panels.

IP65 (front) / IP54 (rear) ensures the ceiling integrity is maintained at all times, even when the cover is removed.

Featuring SmartScan – a revolutionary wireless lighting management system that allows users to monitor their energy performance data and complete operational information for all SmartScan standard and emergency luminaires.

Information is displayed on the SmartScan website which can be accessed from anywhere using a computer, laptop, tablet or smartphone.



TECHNICAL FEATURES

Mounting



Specification



SmartScan Configurations



CONSTRUCTION

- Zinc plated steel body
- **Zinc coated steel frame with welded and finished corners**
- Heavy duty folded steel construction allows full walk on capability
- **Polyester powder coated body and frame**
- Polycarbonate fire-retardant diffuser, TP(a)
- **White EDPM closed cell gaskets**

FINISH

- White (RAL9010, 30% gloss)*
- **Glass and satin opal diffuser**
- *Please confirm colour on order

FEATURES

- Fixed output, 4000K, CRI80 as standard
- **Conforms to FS209E class 1000, ISO14644 class 6 standard**
- Full walk-on capability. Tested to 2.5kN/m2 and forms an integrated part of the working platform
- **Flush-fits in to composite load-bearing ceiling panels of 60-200mm thickness**
- IP65 (front) / IP54 (rear)
- **LUX Guard, LED protection**
- Removable LED platform for improved sustainability and longer life cycle



TECHNICAL DRAWINGS

Dimensions

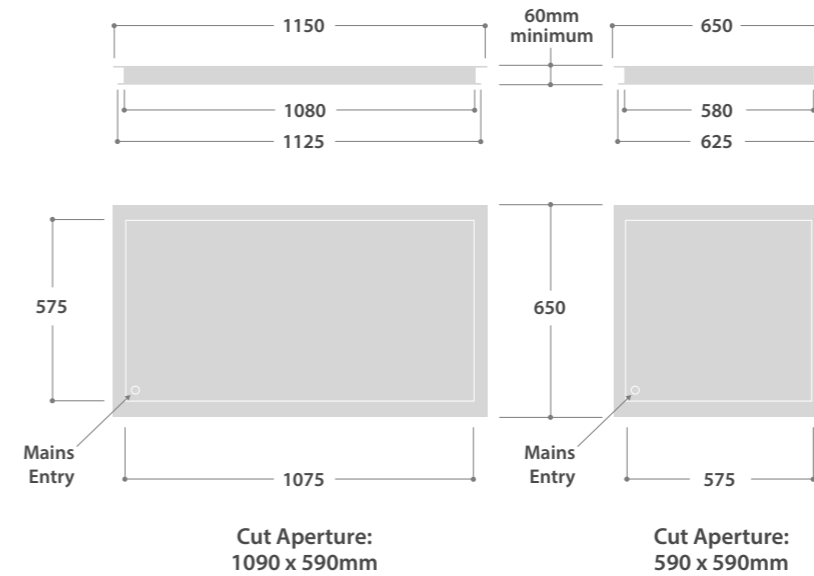

Mounting Arrangement

Load bearing ceiling panel 60mm up to 200mm

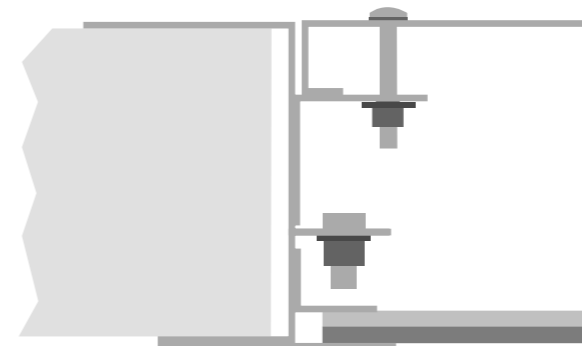

NOTE: The Zeta RA integrates in to the ceiling panel to maintain the working platform in the void space.

BENEFITS & COMPROMISES

Benefits

- Walk-on capability
- Wireless SmartScan control functionality – accessible from anywhere using computer, laptop, tablet or smartphone
- Flush-mounted lux fitting
- Heavy-duty construction

Compromises

- Significantly higher price point
- Potentially longer lead times
- Requires more sophisticated on-going maintenance than other solutions

LED Characteristics

CRI	80+
COLOUR TEMPERATURE	4000K
RATED LIFE (HOURS)	100K - L80/B10
PROTECTION	LUX GUARD
DRIVER EFFICIENCY	>85%
REPLACEABLE	YES
POWER FACTOR	>0.9
LL/CW	111.9

For LED characteristics explanation see www.solite-europe.com/led-guide

APPLICATIONS

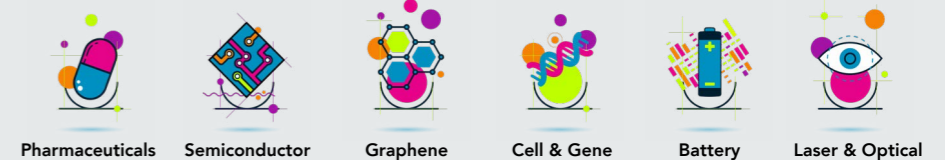

GT Lux Max is designed for applications where walk-on ceiling access is required, allowing for rear-side maintenance, ensuring minimal disruption within your controlled environment. GT Lux Max is the only range of luminaire from the Guardtech Group that is compatible with the wireless SmartScan control system.

LED	CEILING THICKNESS	NOMINAL SIZE	CUT APERTURE	APPROX. kg
38W 45W 54W 75W	60mm - 200mm	600mm x 600mm	590mm x 590mm	17.0
52W 76W 90W 108W	60mm - 200mm	1200mm x 600mm	1090mm x 590mm	30.0

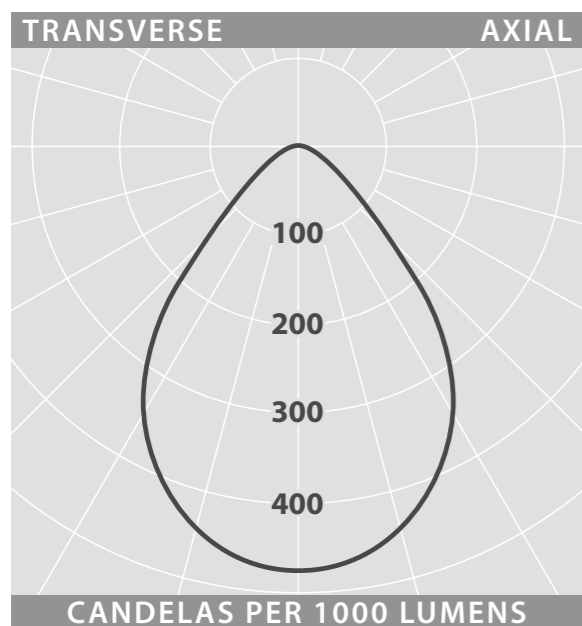

LG7 ENABLING AND CLEAR TOUGHENED GLASS

Luminaire Lumen Output 600 x 600

38W = 4560lm

45W = 5270lm

54W = 6260lm

75W = 8003lm

Emergency = 452lm ▲

Luminaire Lumen Output 1200 x 600

76W = 9120lm

90W = 10540lm

108W = 12520lm

150W = 15505lm

Emergency = 397lm ▲

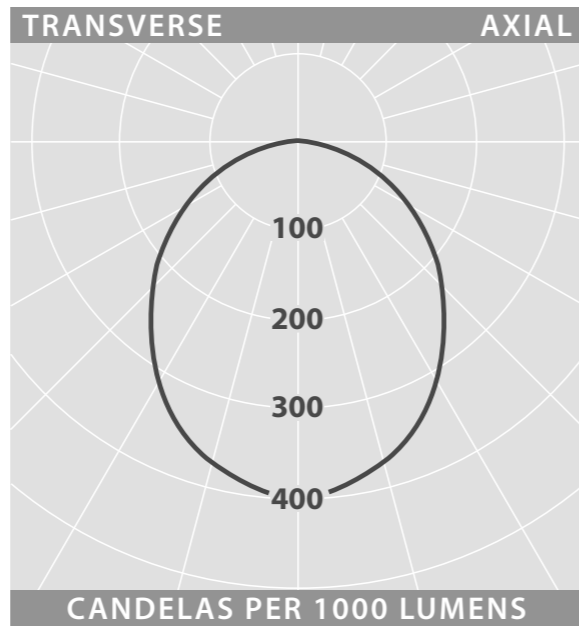

SATIN AND CLEAR TOUGHENED GLASS

Luminaire Lumen Output 600 x 600

38W = 4810lm

45W = 5610lm

54W = 6640lm

75W = 8290lm

Emergency = 426lm ▲

Luminaire Lumen Output 1200 x 600

76W = 9620lm

90W = 11220lm

108W = 13280lm

Emergency = 374lm ▲

OPTIONS

- Special RAL colour**
- **Anti-bacterial paint****
- 150W high output**
- **3000K or 6500K LED light engine****
- CRI90 LED light engine**
- **Stainless steel frame****
- Deglaring lens: LG7 compliant, providing <1500cd/m2. Replace 'TGS' suffix with: '+LG7P' LG7+ clear polycarbonate / '+LG7G' LG7+ toughened glass

Toughened glass front panel:

For applications where corrosive cleaning agents may be applied. Glass is supplied in addition to the satin polycarbonate panel. Replace 'S' suffix with 'TGS' ***Available on request, contact Guardtech sales team*

CONTROL OPTIONS

- DALI or SmartScan

EMERGENCY OPTIONS

3 hour integral***

- Standard, Self-test, DALI or SmartScan
- ***Central battery, contact Guardtech sales team



The SmartScan System exploits the latest digital technology to provide a simple, effective method of lighting control which minimises energy consumption whilst retaining high levels of user comfort.



Movement detection

Presence sensors in all luminaires ensure excellent detection coverage, so that SmartScan luminaires switch on when movement is detected and stay on whilst the space is being used.

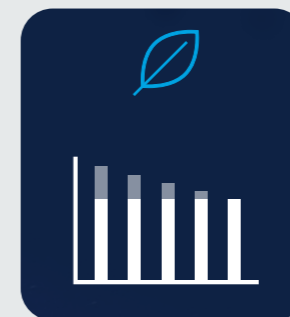

Maintained illuminance

SmartScan luminaires maintain the desired lighting level throughout the maintenance cycle by automatically increasing LED output as the light source ages, avoiding over-lighting new installations.

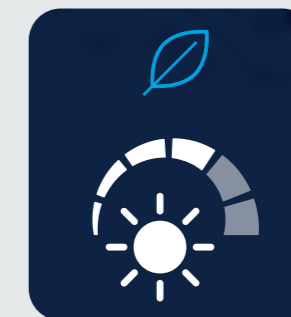

Daylight dimming

When daylight enters an area the SmartScan sensors will take this light into account and gradually dim the LEDs, saving energy whilst maintaining the required light level.

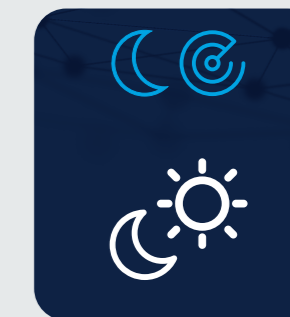

Photocell control

The SmartScan External and Radar Sensors incorporate an ambient light sensor which will enable at dusk and disable at dawn. The luminaire will remain off until movement is detected.



GT LUX PRO

GT Lux Pro is a high-quality and robust LED luminaire with a highly efficient light source – the unit opens from the top, meaning that maintenance is easy and decontamination risks are reduced.



The GT Lux Pro luminaire is made of a steel sheet powder coated in white. The luminaire has been intelligently engineered to allow opening from the top – meaning maintenance can be done without littering facilities.

GT Lux Pro is equipped with a highly efficient LED light source. The luminaire is recommended for use in Pharmaceutical, Electronic and Chemical industries, making it an ideal choice for controlled environments.

• Note: The power shown below refers to the whole system (tolerance +/- 10%). The given luminous flux refers to LED light sources (tolerance +/- 10% depends on the value of the colour temperature).



TECHNICAL FEATURES

LIGHT & ELECTRICAL FEATURES

Light source	LED	
Voltage	220..240 V, 50..60 Hz	
Lifetime of LED sources [h]	100000 (1) / 147000 (2)	
Lx/By	L80/B10 (1) / L70/B50 (2)	
CRI	>80/>90	
SDCM	3	
Operating temperature range [°C]	5 ÷ 30	*Variant to specify when ordering
Driver	Standard on/off (E) DIM DALI (EDD)*	
Power factor cos	>0,95	

MECHANICAL FEATURES

Assembly	For specialty or concrete ceilings
Material	Steel sheet
Colour	RAL 9010 (white)
Diffuser	Micro-PRM (micro-prismatic diffuser PMMA) Micro-PRM SH (micro-prismatic diffuser PMMA with hardened glass) PLX (PMMA opal) SHM (hardened mat glass)



TECHNICAL DRAWINGS

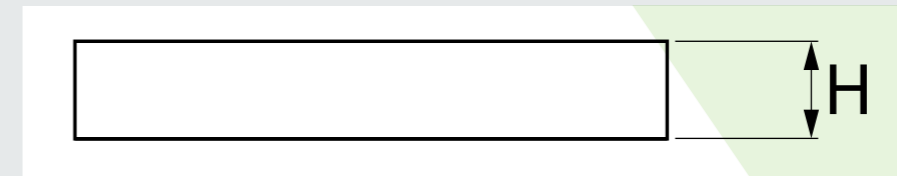
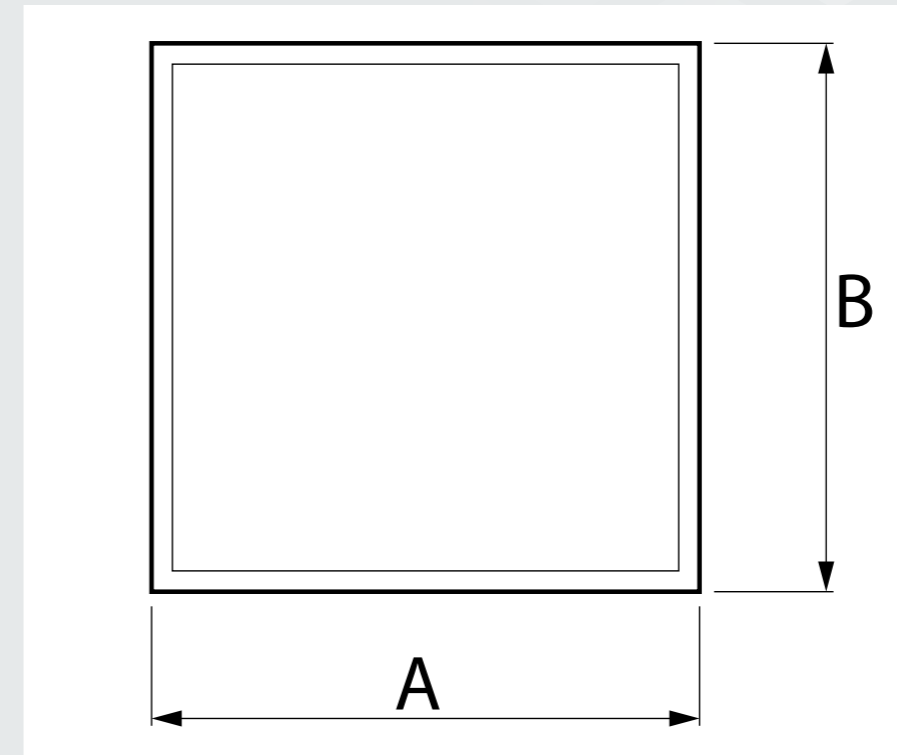

BENEFITS & COMPROMISES

Benefits

- Highly efficient LED
- Opens from top – for easy maintenance and reduction of decontamination risks
- IP65 safety rating
- Good LED lifetime expectation

Compromises

- No supporting DALI system as standard
- No option for surface mounting
- No alternatives on frame colour swatch

MAIN PARAMETERS



Name	Luminous flux LED [lm]	Power of luminaire [W]	Color [K]	Dimensions A x B x H [mm]
TOPAZ ODG CLEAN AL LED 6600	6608 / 6848	35,3	3000 / 4000	657 x 626 x 50-105
TOPAZ ODG CLEAN AL LED 8800	8811 / 9130	49,1	3000 / 4000	657 x 626 x 50-105

APPLICATIONS



GT Lux Pro cleanroom lighting suits a wide variety of applications in a diverse range of sectors. Whilst they may not feature the same high-spec DALI system as standard that GT Lux Max adopts, performance-wise the LEDs are every bit as durable and effective.



GT LUX PLUS



GT Lux Plus (Recessed) is an efficient LED that is recess-mounted in modular, panel and suspended ceilings. The luminaire body is made from steel sheet and powder coated in white.

The GT Lux Plus luminaire is a specially designed recessed LED to be used in modular, panel and suspended ceilings – such as T24 grids. It is equipped with highly efficient LED sources.

The luminaire body is made from steel sheet and powder coated in white. Monolithic construction is the characteristic feature of the luminaire (remaining in one-piece during the exploitation process). Available in PLX or Micro-PRM diffuser.

- Note: The power shown refers to the whole system (tolerance +/- 10%). The given luminous flux refers to LED light sources (tolerance +/- 10% depends on the value of the colour



TECHNICAL FEATURES

LIGHT & ELECTRICAL FEATURES

Light source	LED
Voltage	220..240 V, 50..60 Hz
Lifetime of LED sources [h]	100000 (1) / 147000 (2)
Lx/By	L80/B10 (1) / L70/B50 (2)
CRI	>80
SDCM	3
Photobiological risk class (IEC/EN 62471)	RG0
Operating temperature range [°C]	5 ÷ 30
Driver	Standard on/off (E) DIM DALI (EDD)*
Power factor cos	>0,95

MECHANICAL FEATURES

Assembly	Recess-mounted
Material	Steel sheet
Colour	White
Diffuser	Micro-PRM (micro-prismatic diffuser PMMA) PLX (PMMA opal)

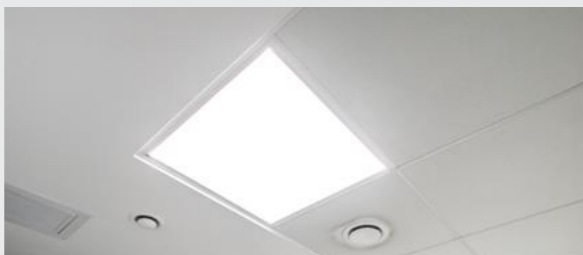

*Variant to specify when ordering



TECHNICAL DRAWINGS

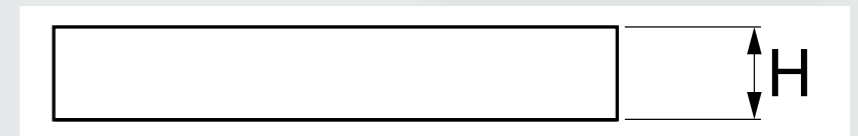
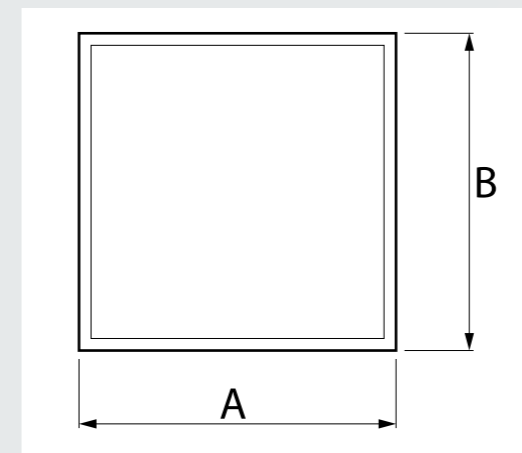
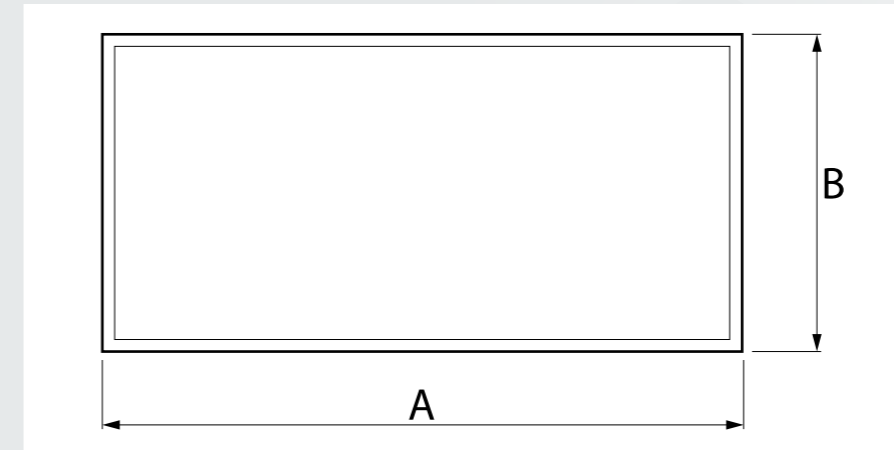

BENEFITS & COMPROMISES

Benefits

- Efficient LED
- More cost effective than GT Lux Max and Pro
- Recess mounted
- Monolithic construction – remains in one-piece during the exploitation process

Compromises

- No supporting DALI system as standard
- No option for surface mounting
- No alternatives on frame colour swatch

MAIN PARAMETERS



Name	Luminous flux LED [lm]	Power of luminaire [W]	Color [K]	Dimensions A x B x H [mm]
AGAT LED 2600	2525 / 2617	14,4	3000 / 4000	596 x 296 x 90
AGAT LED 3900	3788 / 3926	21,7	3000 / 4000	596 x 596 x 90
AGAT LED 4400	4406 / 4565	24,7	3000 / 4000	596 x 296 x 90
AGAT LED 5200	5051 / 5234	28,2	3000 / 4000	1196 x 296 x 90 / 596 x 596 x 90
AGAT LED 6500	6314 / 6543	34,8	3000 / 4000	596 x 596 x 90
AGAT LED 6600	6608 / 6848	35,3	3000 / 4000	596 x 596 x 90
AGAT LED 8800	8811 / 9130	49,1	3000 / 4000	1196 x 296 x 90 / 596 x 596 x 90
AGAT LED 10400	10102 / 10468	56,3	3000 / 4000	1196 x 596 x 90
AGAT LED 11000	11014 / 11413	60,5	3000 / 4000	596 x 596 x 90
AGAT LED 13200	13217 / 13695	71,6	3000 / 4000	1196 x 596 x 90
AGAT LED 17600	17622 / 18261	100,5	3000 / 4000	1196 x 596 x 90

APPLICATIONS



GT Lux Plus is a versatile cleanroom lighting solution suitable for a significant number of different industries using controlled environments as part of their process. This recessed option allows for a more flush finish if required.



GT LUX PLUS



GT Lux Plus (Surface) is a versatile lighting solution for a wide range of applications. This version of GT Lux Plus LED is specially engineered to be surface-mounted on Guardtech ceiling systems.

GT Lux Plus (Surface) is a surface-mounted luminaire equipped in highly efficient LED panels. The LED panel's luminaire body is made from steel sheet and comes powder coated in white.

Diffusers and optical systems are housed in a robust aluminium frame. This high-quality luminaire is recommended for a wide variety of applications utilising controlled environments.



620M x 620M PRODUCT DATA

LIGHT AND ELECTRICAL DATA	
Light source	LED
Luminous flux LED [lm]	11413
LED power [W]	58.5
Luminaire luminous flux [lm]	8563
Power of luminaire [W]	60.5
Luminaire's light efficiency [lm/W]	141.5
Colour of the light [K]	4000
CRI	>80
SDCM (LED sources)	3
Beam angle [°]	(C0-C180) / (C90-C270) - 105°/104,8°

Assembly Surface mounted on ceiling
Material Steel sheet
Colour White
Diffuser PLX (PMMA opal)
Impact resistant IK04
Weight [kg] 5.6
Dimensions [mm] 620 x 620 x 78

LIGHT AND ELECTRICAL DATA	
Photobiological risk class (IEC/EN62471)	RG0
Protection against electric shock	I
Protection degree	IP65
Voltage	220..240 V, 50..60 Hz
Lifetime of LED sources [h]	100000 (1) / 147000 (2)
Lx/By	L80/B10 (1) / L70/B50 (2)q
Operating temperature range [°C]	5 ÷ 30
Driver	Standard on/off (E)
Power factor cos	>0,95
Circuit load capacity	16 (B10), 26 (B16), 23 (C10), 37 (C16)

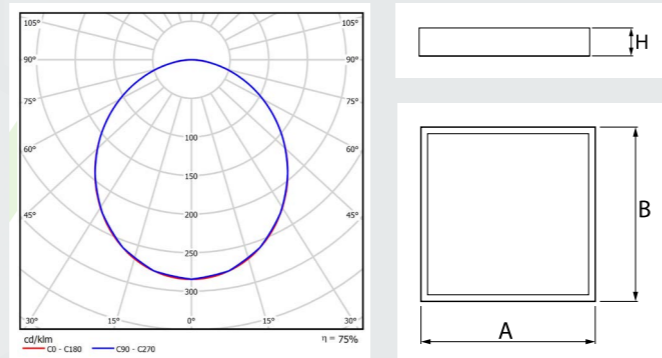

1220M x 600M DATA

LIGHT AND ELECTRICAL DATA	
Light source	LED
Luminous flux LED [lm]	10468
LED power [W]	53.2
Luminaire luminous flux [lm]	7854
Power of luminaire [W]	56.3
Luminaire's light efficiency [lm/W]	139.5
Colour of the light [K]	4000
CRI	>80
SDCM (LED sources)	3
Beam angle [°]	(C0-C180)/(C90-C270) - 105/104,8°
Photobiological risk class (IEC/EN62471)	RG0
Protection against electric shock	I
Protection degree	IP65
Voltage	220..240 V, 50..60 Hz
Lifetime of LED sources [h]	100000 (1) / 147000 (2)
Lx/By	L80/B10 (1) / L70/B50 (2)q
Operating temperature range [°C]	5 ÷ 30
Driver	Standard on/off (E)
Power factor cos	>0,95
Circuit load capacity	16 (B10), 26 (B16), 23 (C10), 37 (C16)

Assembly Surface mounted on ceiling
Material Steel sheet
Colour White
Diffuser PLX (PMMA opal)
Impact resistant IK04
Weight [kg] 9.8
Dimensions [mm] 1220 x 620 x 78

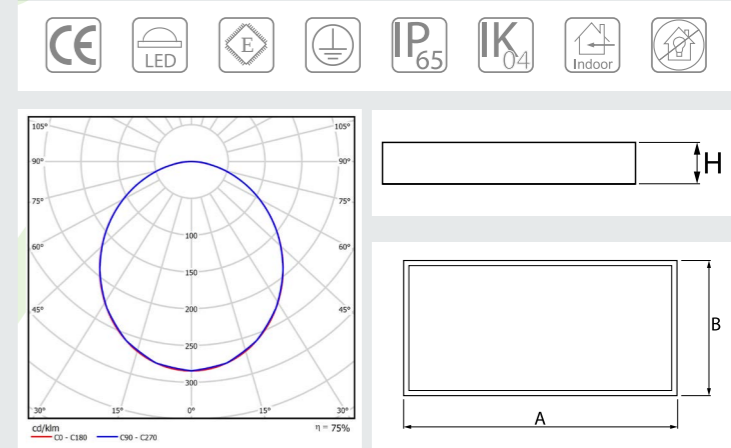

BENEFITS & COMPROMISES

Benefits

- Efficient LED
- More cost effective than GT Lux Max and Pro
- Surface mounted
- IP65 safety rating
- Available in PLX or Micro-PRM diffuser

Compromises

- No supporting DALI system as standard
- No option for recess mounting
- No alternatives on frame colour swatch
- Not as good quality as GT Max or GT Pro

APPLICATIONS



GT Lux Plus is a versatile cleanroom lighting solution suitable for a significant number of different industries using cleanrooms as part of their process.





GT LUX LITE



GT Lux Lite is Guardtech's entry-level light solution – an LED panel that can either be dropped in a grid or surface mounted, with dimmable, DALI dimmable and standard non-dimmable versions available.

The Guardtech Group's entry-level lighting solution includes 1200 x 600 and 600 x 600 options.

Both GT Lux Lite options can be dropped in a grid as a standard recessed solution, but there is also the option of a surface-mount frame.

As well as the flexibility of how they're installed, these ultra efficient, cost-effective LEDs offer a 1-10v dimmable model, a DALI dimmable version and a standard non-dimmable model.

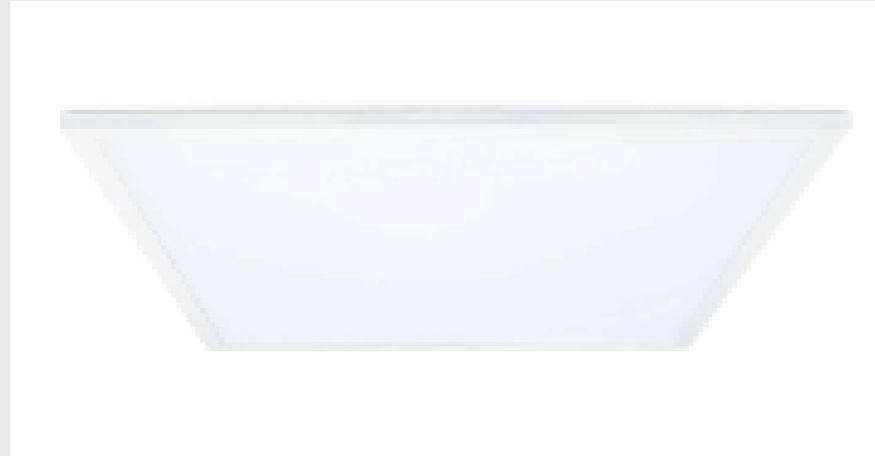

600M x 600M PRODUCT DATA

- UGR <19 as standard
- **Ultra efficient 100LpcW**
- IP44 protection against dust and moisture
- **Comes with non-dimmable flicker free driver with standard model**
- Suspension kit and surface mount box available
- **Compatible with standard and JCC self-test emergency remote packs**
- DALI Dimmable version – comes with dimmable flicker free driver
- **1-10V Dimmable version – comes with dimmable flicker free driver**

RECESSED AS STANDARD

TECHNICAL FEATURES	
Actual Lumen Output	3000
CRI:	Ra 80
Class	Class II, double insulated
Correlated Colour Temperature	5700k
Dimmable	Both dimmable and non-dimmable available

PRODUCT FEATURES	
Energy Rating	This product contains a light source of energy efficiency class F
Guarantee	Two years standard warranty extends to five years when registered within the first year of purchase (including 2 year on site).
IP Rating	IP44
Light Distribution Detail	90-degree
Luminaire Circuit Wattage	30W



1200M x 600M DATA

- UGR <19 as standard
- **Ultra efficient 100LpcW**
- IP44 protection against dust and moisture
- **Comes with non-dimmable flicker free driver with standard model**
- Suspension kit and surface mount box available
- **Compatible with standard and JCC self-test emergency remote packs**
- DALI Dimmable version – comes with dimmable flicker free driver
- **1-10V Dimmable version – comes with dimmable flicker free driver**

TECHNICAL & PRODUCT FEATURES

Actual Lumen Output	4800
CRI:	Ra 80
Class	Class II, double insulated
Correlated Colour Temperature	5700k
Dimmable	Both dimmable and non-dimmable available
Energy Rating	This product contains a light source of energy efficiency class F
Guarantee	Two years standard warranty extends to five years when registered within the first year of purchase (including 2 year on site).
IP Rating	IP44
Light Distribution Detail	90-degree
Luminaire Circuit Wattage	48W

BENEFITS & COMPROMISES

Benefits

- Efficient LED
- More cost effective than GT Lux Max and Pro
- Option for either surface or recess mounting
- DALI dimmable and standard non-dimmable versions available
- The most cost-effective option in the range

Compromises

- No supporting DALI system as standard
- Lower quality level than GT Max or GT Pro
- No alternatives on frame colour swatch

SURFACE MOUNTING

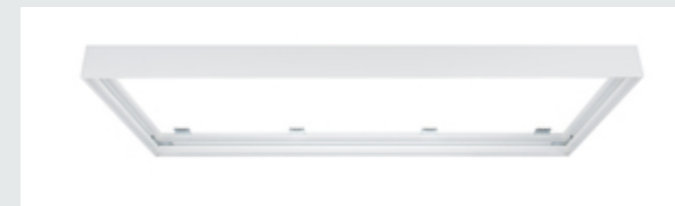

- Surface mounting tray for 1200 x 600 panels
- Suitable for Remote Emergency packs
- White finish • Product Shape: rectangle
- Weight: 9.4kg
- Dimensions: L 1200 x W 300 x D 75
- CE Marked • UKCA Marked
- WEEE Symbol • Certificate Of Conformity
- Accredited Members: LIA, ISO9001-2015, ISO14001-2015

- Surface mounting tray for 600 x 660 panels
- Suitable for Remote Emergency packs
- White finish • Product Shape: square
- Weight: 4.765kg
- Dimensions: L 600 x W 600 x D 75
- CE Marked • UKCA Marked
- WEEE Symbol • Certificate Of Conformity
- Accredited Members: LIA, ISO9001-2015, ISO14001-2015

APPLICATIONS



GT Lux Lite suits the least demanding of applications – most commonly laboratories or non-classified controlled environments.



GT LUX FIRE

GT Lux Fire is Guardtech's fire-rated lighting solution – a high-quality recessed LED luminaire with a corrosion-resistant, zinc-coated steel body that meets the requirements of Zone 1 hazardous areas.



The GT Lux Fire is a recessed LED luminaire specifically designed for use in cleanrooms and clean areas such as in the Pharmaceutical, Oil & Gas, Chemical and Process industries.

Tried and tested, the GT Lux Fire luminaire is suitable for the most sensitive of cleanrooms whilst meeting the requirements of Zone 1 hazardous areas. Suitable for both modular and non-modular applications, the GT Lux Fire is available for installation into Spring Tee, T25 Grid and Cut Aperture ceilings.

Innovation, integrity and performance are the first principles involved in the design and construction of clean, controlled and sterile environments. Innovation in design and engineered to perform, the integrity of your cleanroom is guaranteed with GT Lux Fire.



IP66

WARRANTY
5YR

LED

IK10
30J

ATEX

L80
B20

TECHNICAL FEATURES

- Power Supply: 220-254V AC/DC, 50/60Hz
- Terminals: 3 core 4mm² conductors with looping and 16A rating through wiring (4 core on emergency)
- Cable Entries: 4 x 20mm clearance holes located on top, two each side
- Surge Protection: 4kV
- Insulated Ambient Temperature Range: -20°C to +45°C



CONSTRUCTION

With a fully welded construction the GT Lux Fire luminaire has a corrosion resistant, zinc coated steel body and extruded aluminium front frame with a durable polyester paint finish.



MATERIALS



- Enclosure : White polyester painted zinc coated steel body and aluminium frame. Frame colour RAL9016G
- Diffuser: Clear polycarbonate with prismatic diffuser
- Fixing Details: Side brackets with adjustable arms (solid ceilings) with provision for drop rod mounting
- Emergency Operation: 90mins (30% output)
- 3 Hour Emergency version: 3 hour battery duration (15% output)
- Battery: 6V Internal Ni-Cad (Emergency version only)

CERTIFICATIONS & APPROVALS

- Protection Type: Ex e mb q (Increased Safety, Encapsulation, Powder filling)
- ATEX Classification: Group II Category 2 GD
- Area Classification: Zone 1 and 21 areas to EN 60079-10-1 and EN 60079-10-2 with installation to EN 60079-14
- EC Type Examination Certificate: CML16ATEX3335
- IECEx Certificate of Conformity: IECEx CML16.0108X
- Coding: Ex eb mb op is q IIC T4 Gb, Ex tb IIIC T95°C Db IP65
- Ambient temperature range: -20°C to +40°C
- Ingress protection to IP65 to EN 60529
- SOLAS B15 Fire rating - appropriate insulation is required over the luminaire



BENEFITS & COMPROMISES

Benefits

- ATEX rated option
- Meets the requirements of Zone 1 hazardous areas
- Corrosion-resistant, zinc-coated steel body
- IP66 safety rating
- Compatible with a range of grid systems
- Surge protection of 4kV

Compromises

- More expensive solution than GT Lite, Plus and Pro
- Potentially longer lead times than other options
- No option for surface mounting

APPLICATIONS



GT Access Fire is a fire-rated cleanroom lighting solution that can be adopted throughout a number of different sectors where there is a concerted requirement for fire safety, either from a compliance perspective or as part of a business' wider policy and expectations.



TECHNICAL DRAWINGS

SPECIFICATIONS

Dimensions	Lumen Output	Wattage	Weight (kg)
600 x 600	3407lm	60w	16.0

OPTIONS

Extra live termination facility (compatible with 4 core switched emergency circuits)
25mm Cable Entries
Screw Connection Terminal Block (6mm ² Conductors)
Specific Voltage (110/130V)
Geartray isolation switch

COOL TEMPERATURE OPTIONS

4000K - Neutral White
6000K - Cool Daylight



EMERGENCY OPTIONS

Integral 3 Hour Emergency
Integral 90 min Emergency

T25 GRID

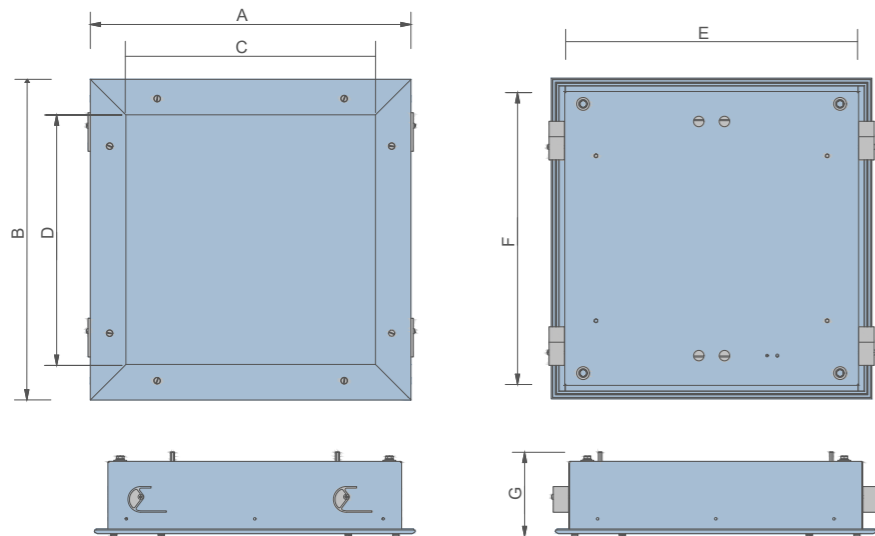

Dimensions (mm)						
A	B	C	D	E	F	G
624	624	486	486	572	572	159

Installation detail

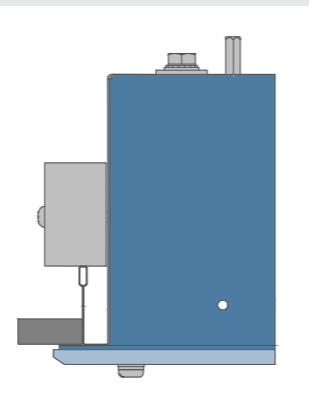

SPRING TEE

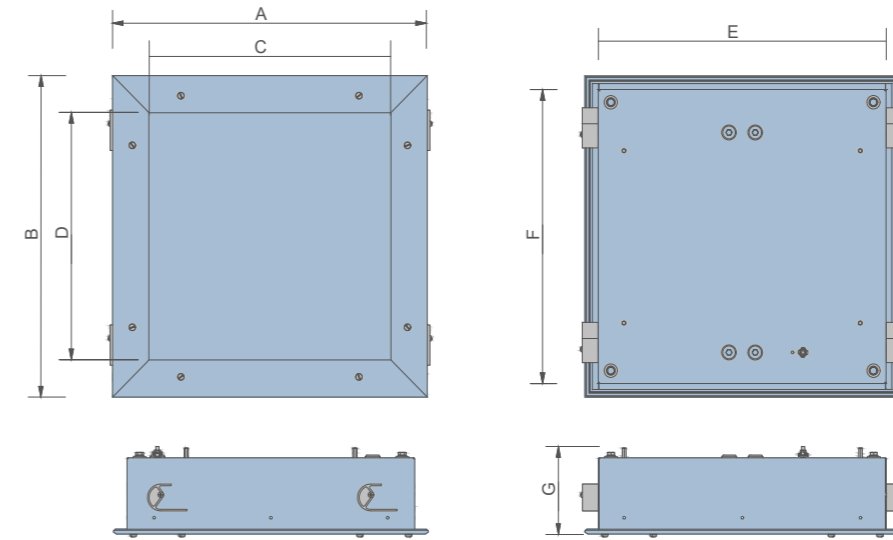

Dimensions (mm)						
A	B	C	D	E	F	G
599	599	461	461	548	548	160

CUT APERTURE

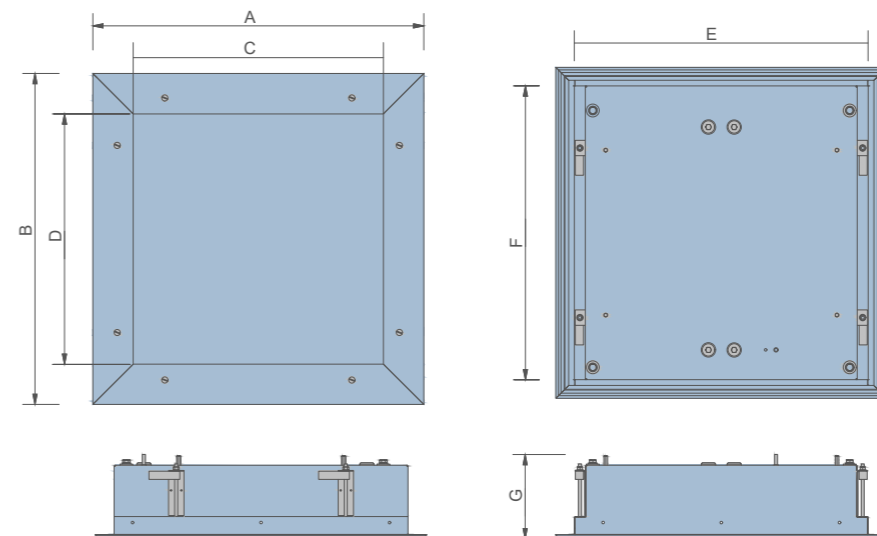

Dimensions (mm)						
A	B	C	D	E	F	G
644	644	487	487	572	572	163

Installation detail

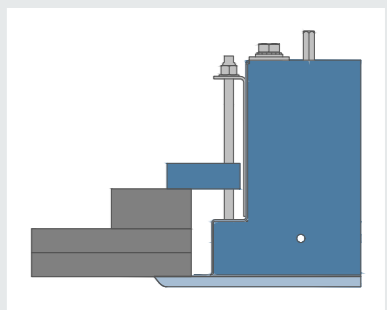

Installation detail

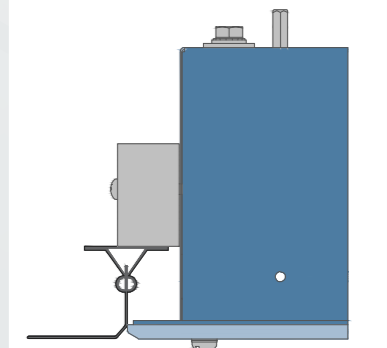

DALI SYSTEM

Digital Addressable Lighting Interface



DALI stands for Digital Addressable Lighting Interface and is a two-way open communications protocol to enable lighting to become smart/intelligent.

Interoperability standards and Mandatory certification to IEC62386 ensure compatibility between lighting manufacturers.

All GT Lux light fittings are compatible with DALI and this can be operated through the Building Management System (BMS), for more information please see the GT Scan Technical Data Sheet.

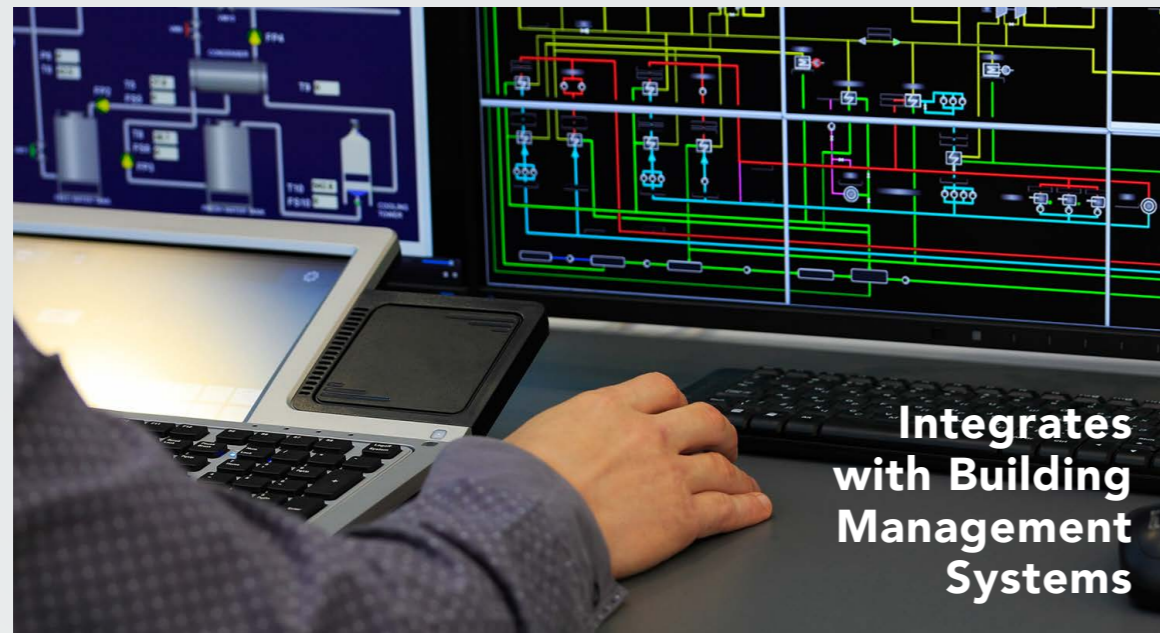

Flexibility

DALI allows for a wide range of lighting control options, including dimming, scene setting and daylight harvesting. This makes it a suitable choice for a variety of lighting applications. DALI enables building and facilities managers to control the lighting network remotely.

Scalability

DALI can control up to 64 lighting devices with a single control device, making it a scalable solution for large lighting installations. Can also be integrated into your own existing Building Management System (BMS) as DALI utilises open protocols.

Improved lighting quality

DALI allows for precise control of lighting levels, which can improve the overall quality of lighting in a space and enhance the user experience.

DALI allows for precise control of lighting levels, which can help reduce energy consumption and lower costs.

This intelligent solution gives users the ability to increase the output to the lamps as they deteriorate over time, maintaining lighting levels and extending the life of the lamps in use.



Other benefits of operating a DALI system

- Faulty lamps can be identified remotely.
- Automatic Function and Duration Testing of emergency lighting – including reporting back to BMS.
- Wiring is straightforward, a relatively high bus voltage (16V) and slow data speed (1,200 baud) mean that mains flex can be used and specialist screen cable isn't required.
- Installation and commissioning errors are minimised with a wide range of wiring topologies supported.

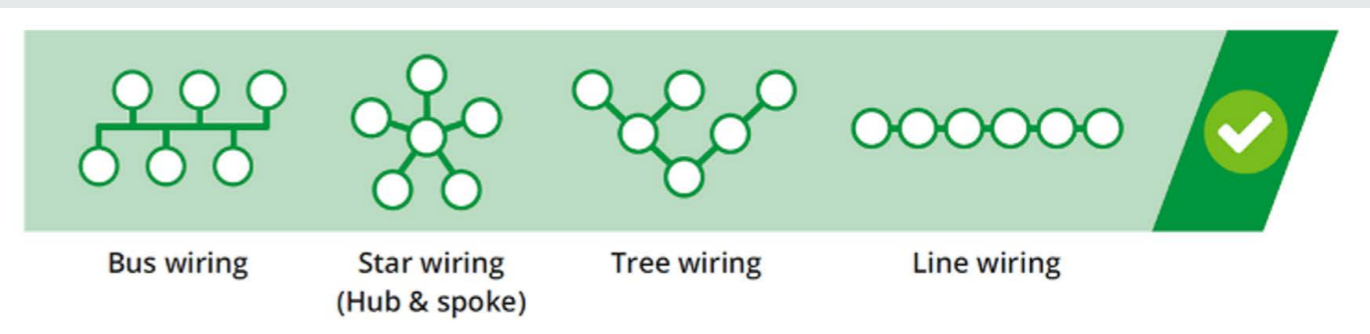



QUICK-LOOK COMPARISON GUIDE

FEATURES



FEATURES	MAX	PRO	PLUS	LITE
DALI compatible	<input checked="" type="checkbox"/>	<input checked="" type="checkbox"/>	<input checked="" type="checkbox"/>	<input checked="" type="checkbox"/>
Walk-on capability	<input checked="" type="checkbox"/>	<input checked="" type="checkbox"/>	<input type="checkbox"/>	<input type="checkbox"/>
Flush mounted	<input checked="" type="checkbox"/>	<input checked="" type="checkbox"/>	<input type="checkbox"/>	<input type="checkbox"/>
Surface mounting option	<input type="checkbox"/>	<input type="checkbox"/>	<input checked="" type="checkbox"/>	<input checked="" type="checkbox"/>
4000k colour temperature	<input checked="" type="checkbox"/>	<input checked="" type="checkbox"/>	<input checked="" type="checkbox"/>	<input type="checkbox"/>
Grid mounting option	<input checked="" type="checkbox"/>	<input checked="" type="checkbox"/>	<input checked="" type="checkbox"/>	<input checked="" type="checkbox"/>
Rear access	<input checked="" type="checkbox"/>	<input checked="" type="checkbox"/>	<input type="checkbox"/>	<input type="checkbox"/>
Comes with SmartScan system as standard	<input checked="" type="checkbox"/>	<input type="checkbox"/>	<input type="checkbox"/>	<input type="checkbox"/>
IP65 Protection	<input checked="" type="checkbox"/>	<input checked="" type="checkbox"/>	<input checked="" type="checkbox"/>	<input type="checkbox"/>
Stainless steel frame	<input checked="" type="checkbox"/>	<input checked="" type="checkbox"/>	<input checked="" type="checkbox"/>	<input checked="" type="checkbox"/>
Movement detection	<input checked="" type="checkbox"/>	<input type="checkbox"/>	<input type="checkbox"/>	<input type="checkbox"/>





Guardtech

group

www.guardtech.com

Unit C
The Brocks Business Centre,
Homefield Road,
Haverhill, Suffolk,
CB9 8QP